

Digital Linear-turn Electric Actuator

Instruction Manual



Tianjin Freya Automation Technology Co.,Ltd



Product Description:

FRY-Y series digital intelligent linear-turn electric actuators are mainly used in petrochemical, pharmaceutical, various power plants, new materials, new energy, central air conditioning, urban heating and other industries.

The actuator debugging operation process is completely suitable for valve debugging. It uses an absolute encoder with stable performance, high precision, simple and convenient debugging, and achieves on-site debugging and remote control.

Main Parameters:

Maximum stroke: 30mm, 60mm, 100mm. Voltage: AC220V. Speed: 30%-100% of the maximum operating speed. Stroke setting: digital stroke setting. Thrust: 1000N-12000N. Status display: LED display. Ambient temperature: -20°—80°C. Protection grade: IP65. Shell: hard aluminum alloy and electrostatic spraying.

Overview

This control unit uses brushless DC drive technology and is divided into two parts: a control panel and a display panel. The control panel is responsible for signal acquisition and processing and driving the brushless DC motor. The display panel is responsible for data interaction with the user. This control unit is easy to operate and has the following features in addition to some basic functions:

1. **Stepless speed regulation:** The menu can set the motor speed and the deceleration distance in position, with stable performance and high precision;
2. **Encoder selection:** The Hall inside the brushless DC motor can replace the encoder for precise positioning. It needs to return to zero position every time it is powered on. The user can choose the positioning method as needed;
3. **Arbitrary combination of input and output signal types:** Arbitrarily switch between 4-20mA, 0-10V and other signals through the menu.

Model Description

Name: Control unit for control valve mechanism (divided into accessories such as main control panel, display panel)

Technical Parameters

1. Working voltage: single-phase 220VAC, three-phase 380VAC optional;
2. Working temperature: -20°C-70°C;
3. Storage temperature: -40°C-85°C;
4. Operating humidity: $\leq 90\%RH$, no condensation, no strong corrosive, flammable and explosive gas or dust around;
5. Return difference: $\leq 0.5\%$;
6. Dead zone: 3%-1.5% adjustable;
7. Basic error: $\leq 0.5\%$;
8. Analog signal feedback: Feedback the current valve opening, DC4-20mA active current signal and DC0-10V active voltage signal menu optional, load capacity $\leq 500\Omega$;
9. Switch signal feedback: 4 sets of relay switch signals, including remote status, fault

- status, end position open, and end position close;
10. Switch signal input: it can detect remote open, close, and stop of three switch values;
 11. Analog signal input: it can detect input opening signal, DC4-20mA current signal and DC0-10V voltage signal menu are optional;
 12. Remote control bus: Modbus-RTU protocol (customization required);
 13. Signal isolation: Each input and output terminal is isolated by relays and photoelectric couplers, and can withstand 2000V surge voltage;
 14. Full Chinese LCD display: Chinese menu display, convenient for users to observe status and operation.
 15. Fault self-diagnosis function: protection is automatically executed when a fault occurs, and the cause of the fault can be displayed on the screen.

Working principle of transducer

Transducer are widely used in industry production areas. We successfully introduced variable-frequency technique into actuator control and realized the adjustment function of speed, turning and torque to optimize the control of valve.

Timing principle of AC frequency conversion

According to principle of motor, the speed of AC asynchronism motor can be expressed by the following formula:

$$n = 60f/p(1-s)$$

n-Motor speed; p-Motor magnetic pole logarithm
f-Current frequency; s- Turning difference rate

From this formula turning speed of motor can be caused by: Motor magnetic pole logarithm p, turning difference rate s and current frequency f. Changing current frequency can realize adjustment speed of motor, viz. frequency conversion adjustment speed.

To realize the function of transducer: adopt AC-DC-AC variable-frequency way and consists of commutate and adverse change circuits.

1. Commutate

Three-phase AC can commutate via IGBT. Transform AC voltage to DC voltage.

2. Limit current and filter

Filter capacitance C_{zk} filtrate voltage wave after commutating and keep voltage balance when load is changing. When transducer is power on, instantaneous shock current is high. In order to protect circuit components, add limit current resistance R_v. After some time close switch via control circuit and make the limit current resistance to short circuit.

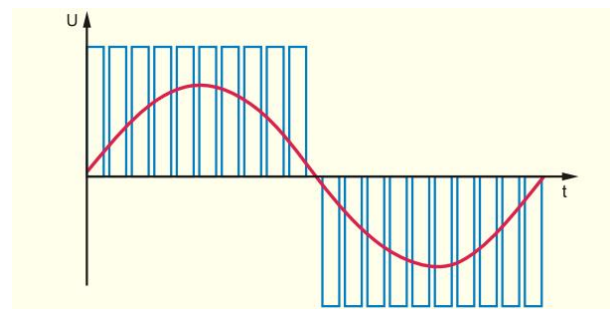

3. Adverse change (DC-AC) modulate with pulse width

Via three-phase adverse bridge which made up of adverse switch tube (IGBT), apply SPWM technology and combine special counting, control rotation speed, rotation direction and torque.

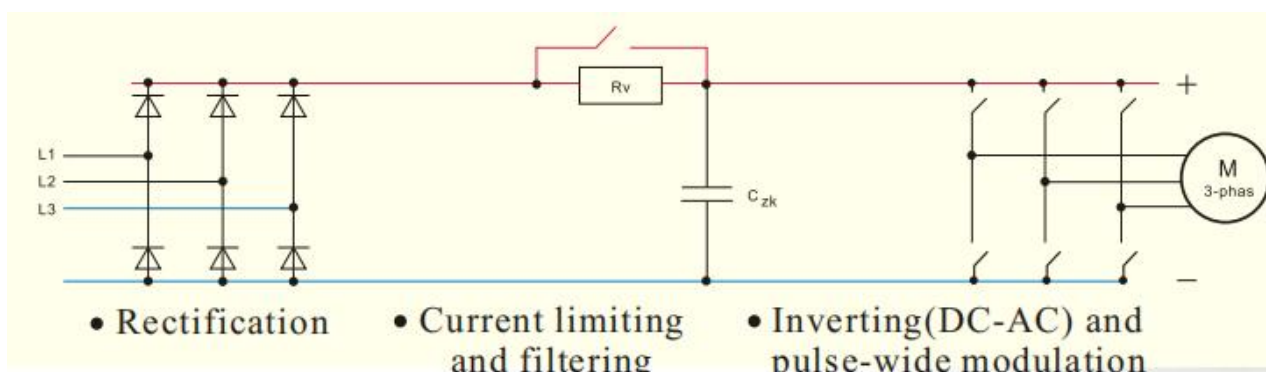

Build-in transducer

Build-in transducer of actuator have more functions and advantages than traditional actuator, better protection of valve and more excellent control.

Flexible control

When valve start, actuator operate in low speed and high torque. When valve approach full-open and full-close position, actuator can reduce speed automatically and run with low speed in terminal position and avoid the collision to valve because of inertia, protect valve and extend lifetime.

Independent setup of full-open/full-close speed and torque, optimized valve control

According to actual need of control process, the speed of open and close directions can be set separately and independently (5% of step length), torque(10% of step length), satisfy different processing or requirement of different running steps and realize optimization of control process.

Multi-protection to ensure the safety of system and actuator, protect motor from overheating.

Realize the precise test of torque, current and temperature via sensor and realize the valid protection from over-flowing, over-heating and over-torque.

Automatic identification of power supply phase

Because of intelligent technology, product can identify power phase automatically, power line can be connected at will, installation and adjustment are simple and quick. Because variable- frequency technology are adopted, it can avoid the effect to power frequency and voltage fluctuating.

Unique EMC filtering circuit and raise anti-interference capacity effectively

Special EMC filtering circuit can avoid interference from environment and raise stability and it can also avoid pollution of electric network from product operation.

Torque speed can be adjusted, reduce stock and save cost

Shut-off torque and output turning speed can be set in large range. Equipped few types of multi-turn actuators with corresponding reducer or linear thruster to buildup multi-torque actuator. Linear actuator 4KN-40KN, Lever actuator 40Nm-36000Nm. Stock for actuators and spare parts can be reduced.

Sensor

Two components located in 90° installed out of motor shaft, 24 magnetic pole rings installed on motor shaft, 48 voltage pulse are produced when motor operate one turn. Pulse signal get the accurate displacement, turning and speed via microprocessor. Position testing is processing and every change can be tested and stored. The sensor is not effected by ambient temperature, stable

function, high measuring precision, strong anti-interfere, long life and no abrasion.

Midway limit position protection function

Through sensor the actual position of actuator can be tested accurately.If reach the position you setup,CPU can output on-off position signal by controlling relay.

When reach full open or close position,CPU control transducer to switch off motor power and realize limit position protection.

Data are independent of battery and can be saved long term.

Because special data process and storage way, operating data can be saved long term under situation of power off to realize permanence and safety of data.

Build-in Li is effective under the situation of power off, handwheel operation and recording valve position change. On the other hand it can be used to check current data when power off.

Electric torque testing replace mechanical torque switch

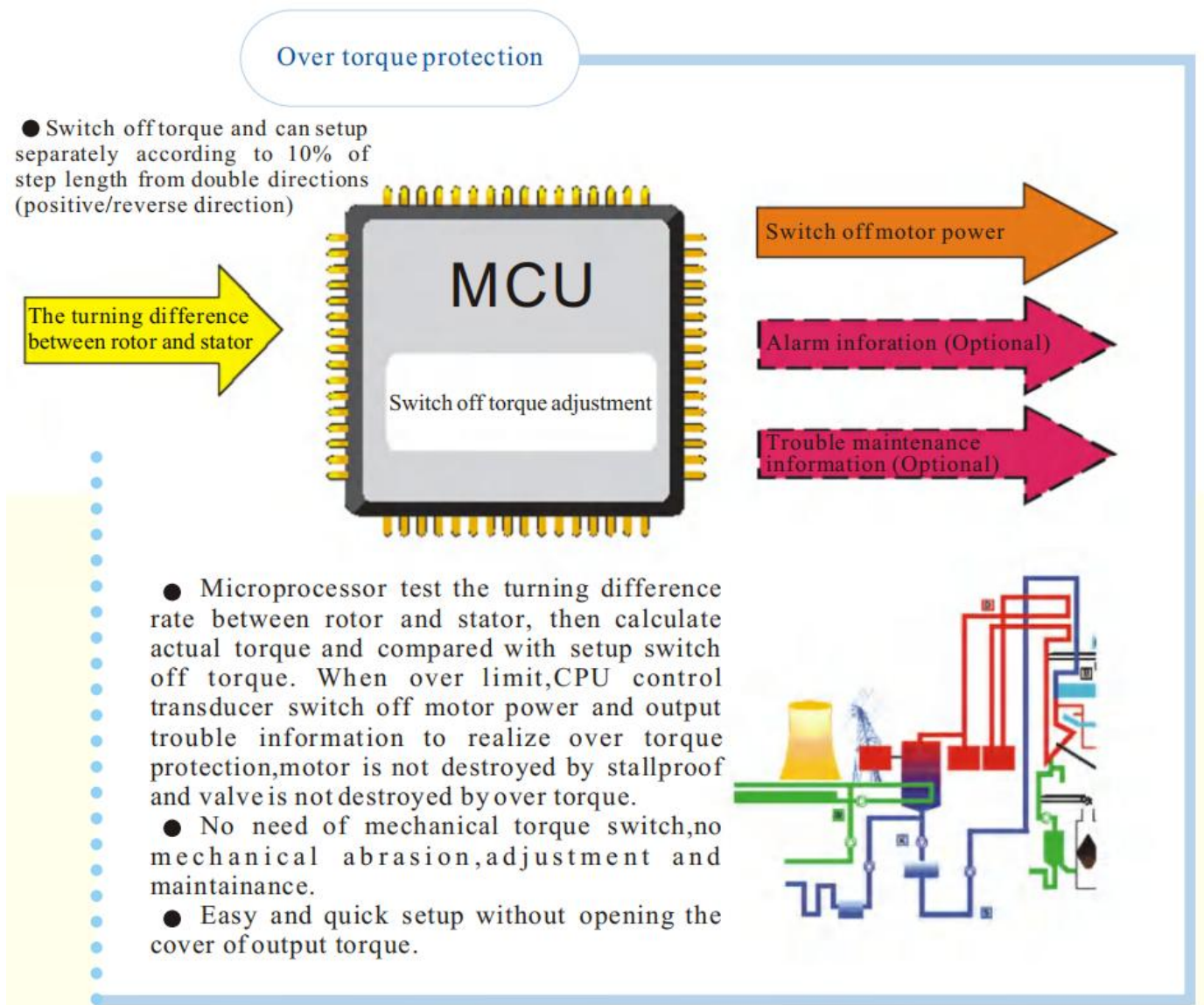

FRY-Y-30 connection dimensions:

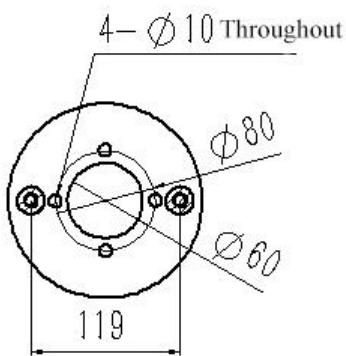
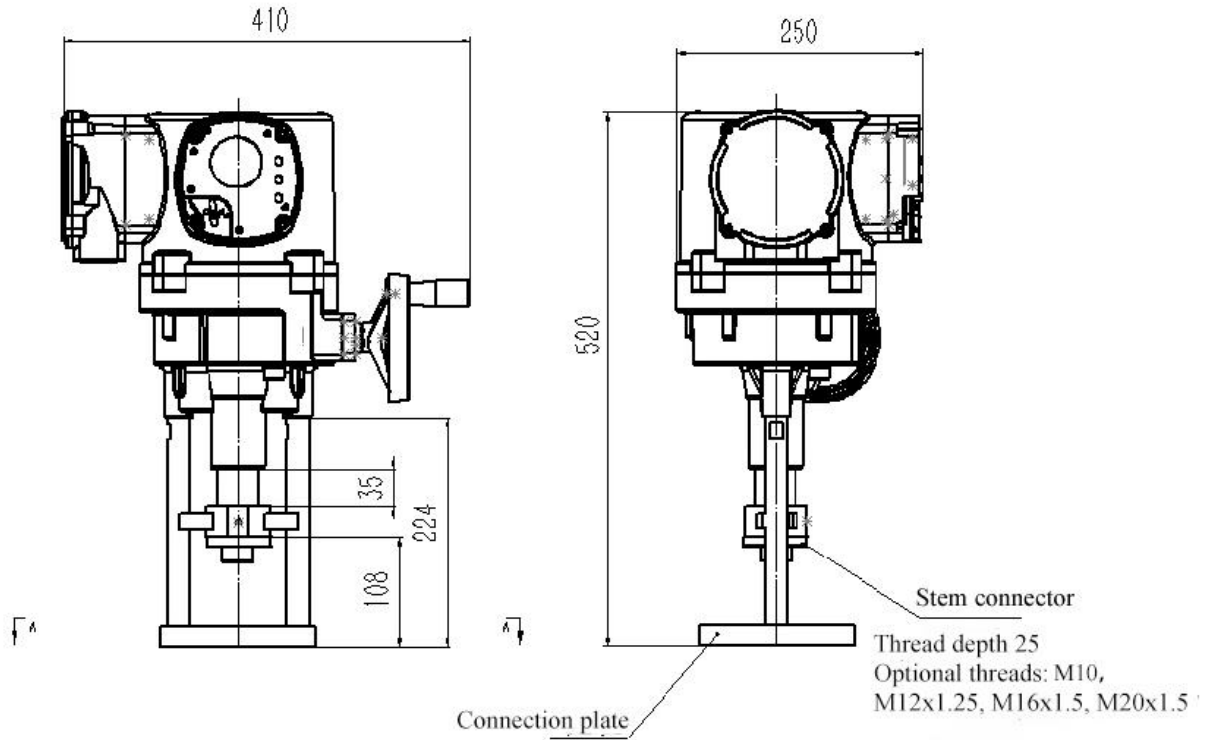

A type connection plate

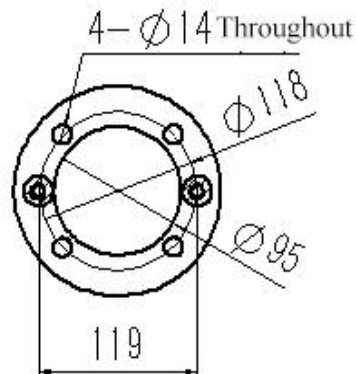

B type connection plate

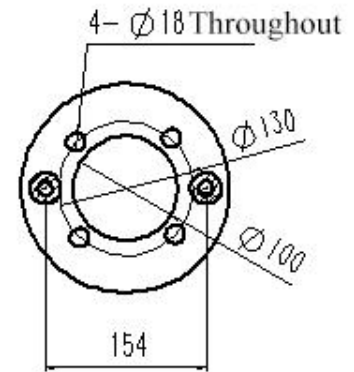

C type connection plate

FRY-Y-60 connection dimensions:

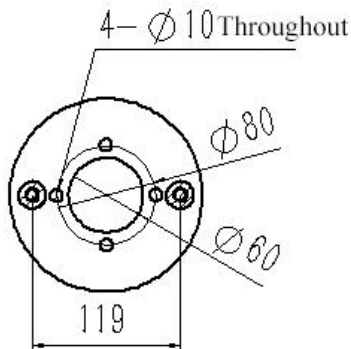
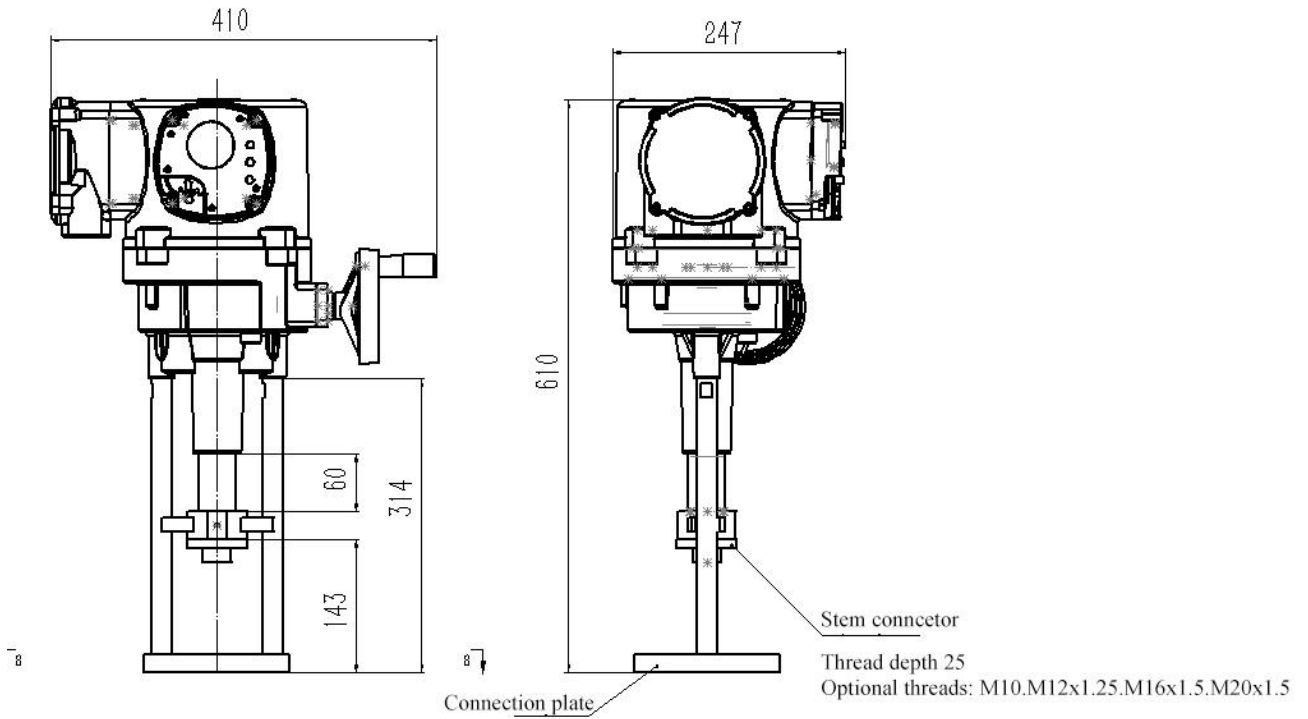

A type connection plate

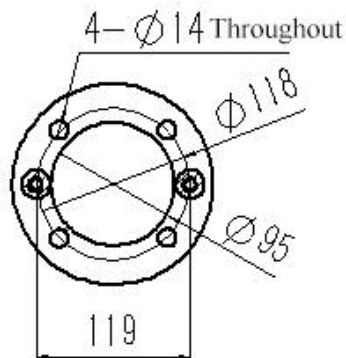

B type connection plate

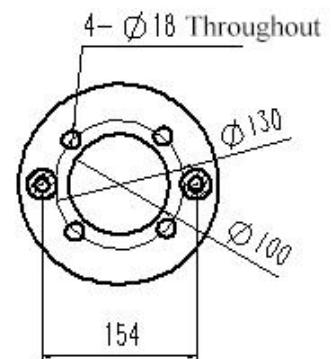

C type connection plate

FRY-Y-100 connection dimensions:

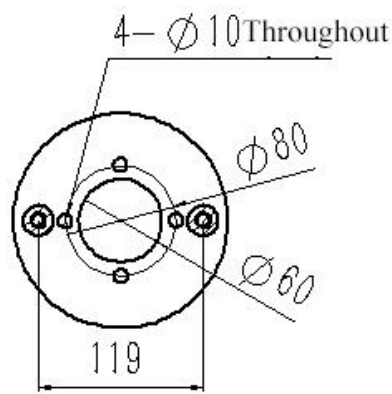
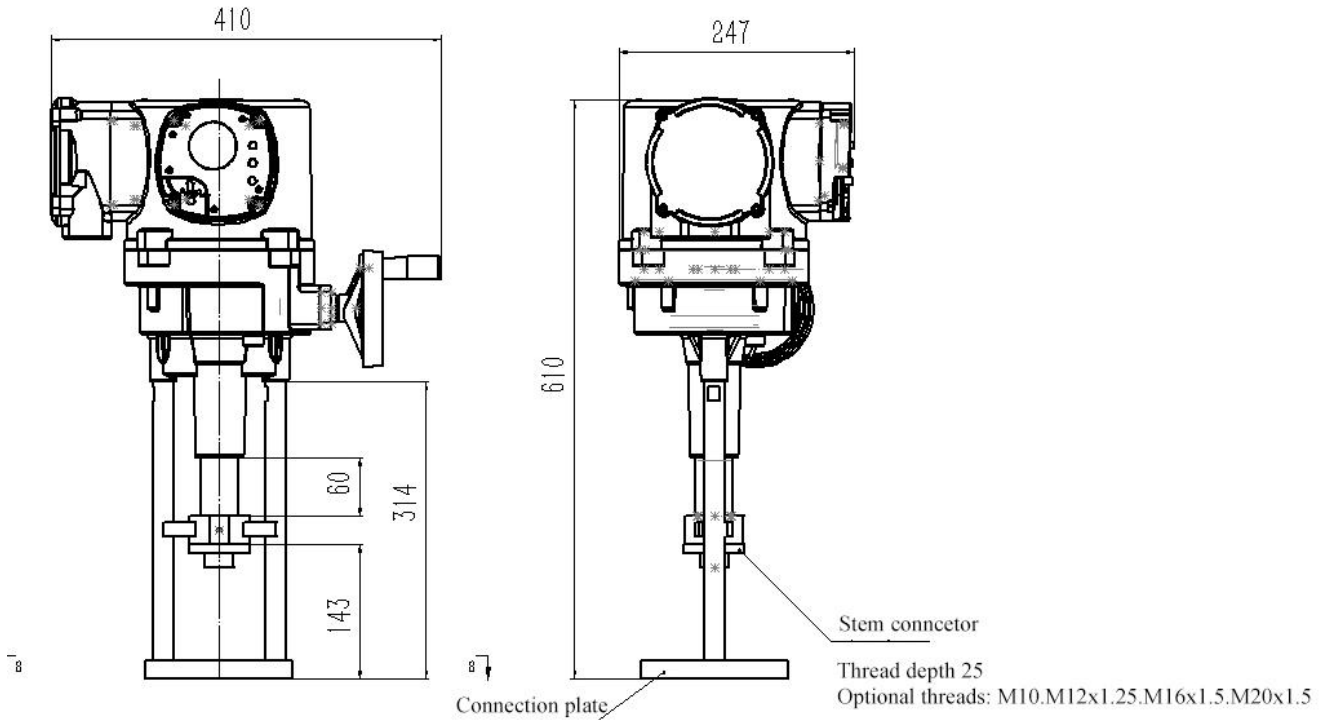

A type connection plate

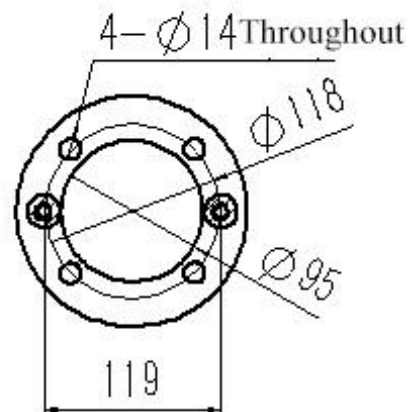

B type connection plate